

CM 90S4

Gru idraulica a montaggio rapido

Hydraulic crane with quick assembling
Grue hydraulique à montage rapide
Hydraulischer Schnellmontagekran
Grúa hidráulica de montaje rápido

serie performance

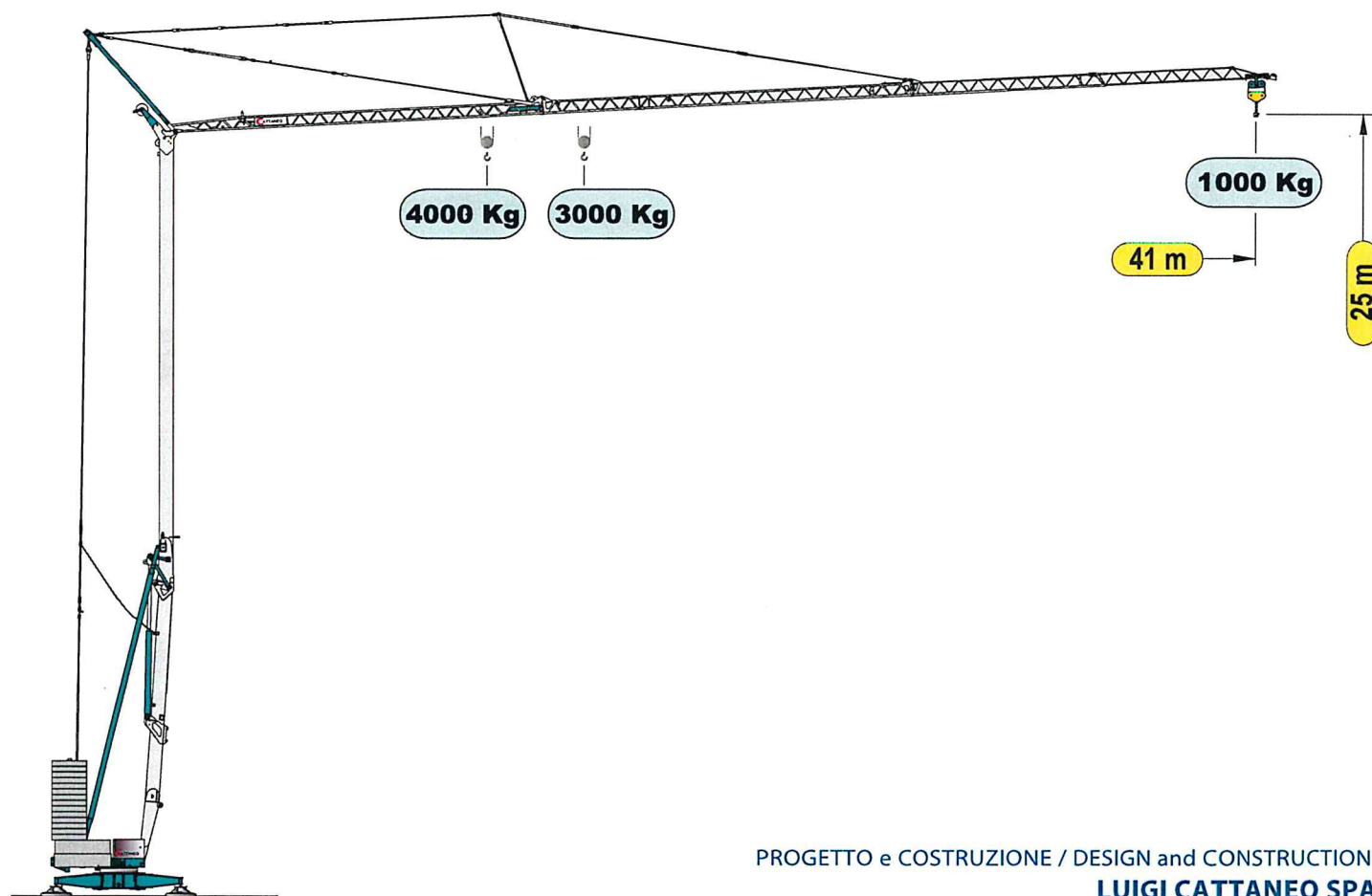

PROGETTO e COSTRUZIONE / DESIGN and CONSTRUCTION :
LUIGI CATTANEO SPA

La LUIGI CATTANEO S.p.A. ringrazia le proprie maestranze, i tecnici progettisti, i responsabili della produzione, i fornitori e tutti coloro che hanno collaborato con entusiasmo alla realizzazione di questo ambizioso progetto. Un ringraziamento va anche ai clienti che ci dimostrano la loro fiducia e ai collaboratori che si impegnano a far conoscere questa macchina sul mercato.

www.cattaneogru.it

CATTANEO



EN 14439 C25

DIN 15018-H1/B3

CM 90S4

 Nessun componente elettrico sul braccio e sulle parti alte della gru
No electrical component on the jib and the top of the crane

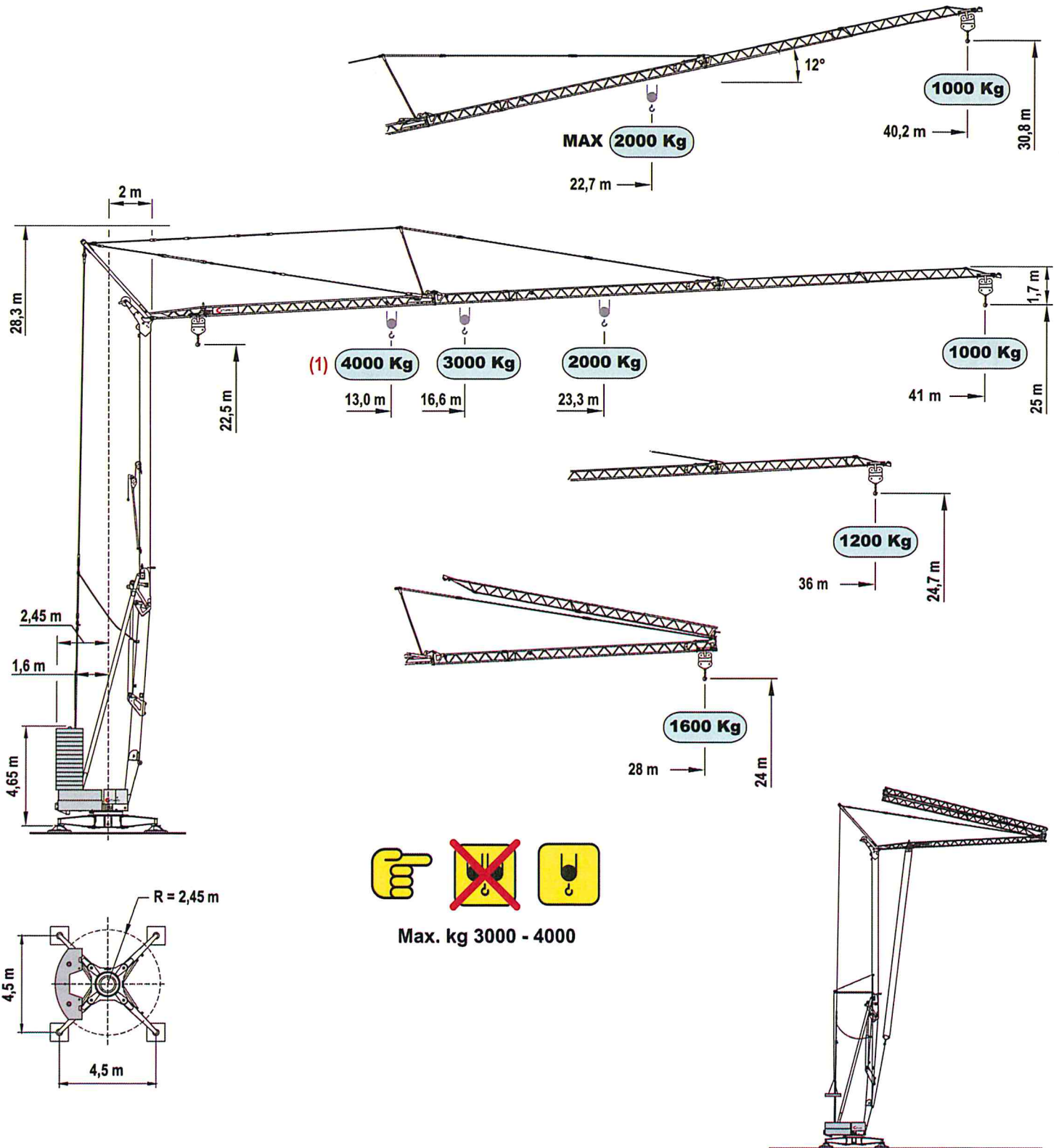

Curve di carico	kg	4000	3000	2500	2000	1900	1800	1700	1600	1500	1400	1300	1200	1100	1000
Load diagrams	m	13.0	16.6	19.3	23.3	24.2	25.3	26.5	27.9	29.4	31.1	33.1	35.5	37.8	41.0
Courbes de charge	m	13.1	16.9	19.6	23.6	24.6	25.8	27.0	28.4	30.0	31.7	33.7	36.0		
Lastkurven	m	13.0	16.6	19.4	23.3	24.3	25.4	26.6	28.0						
Curvas de cargas	m				22.7	23.7	24.8	26.0	27.4	28.8	30.5	32.4	34.6	37.0	40.2

Prestazioni - Performances - Prestations - Leistungen - Prestaciones

Icona	kW	400V - 50Hz			
		1°	2°	3°	4°
 inverter	kW/g/min				
	11/1400 (1) 18,5/1400	↑↓ kg	3000	3000	1500
 inverter	3/1400	m/min 10 - 25 - 50			
	3,7/900	g/min 0,2 - 0,5 - 0,9			

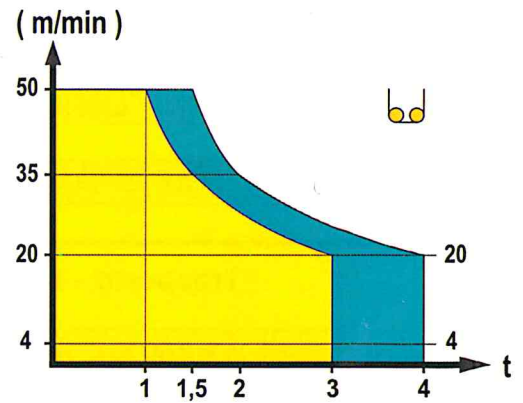

(1) Optional

Montaggio - Erection - Montage - Montage - Montaje

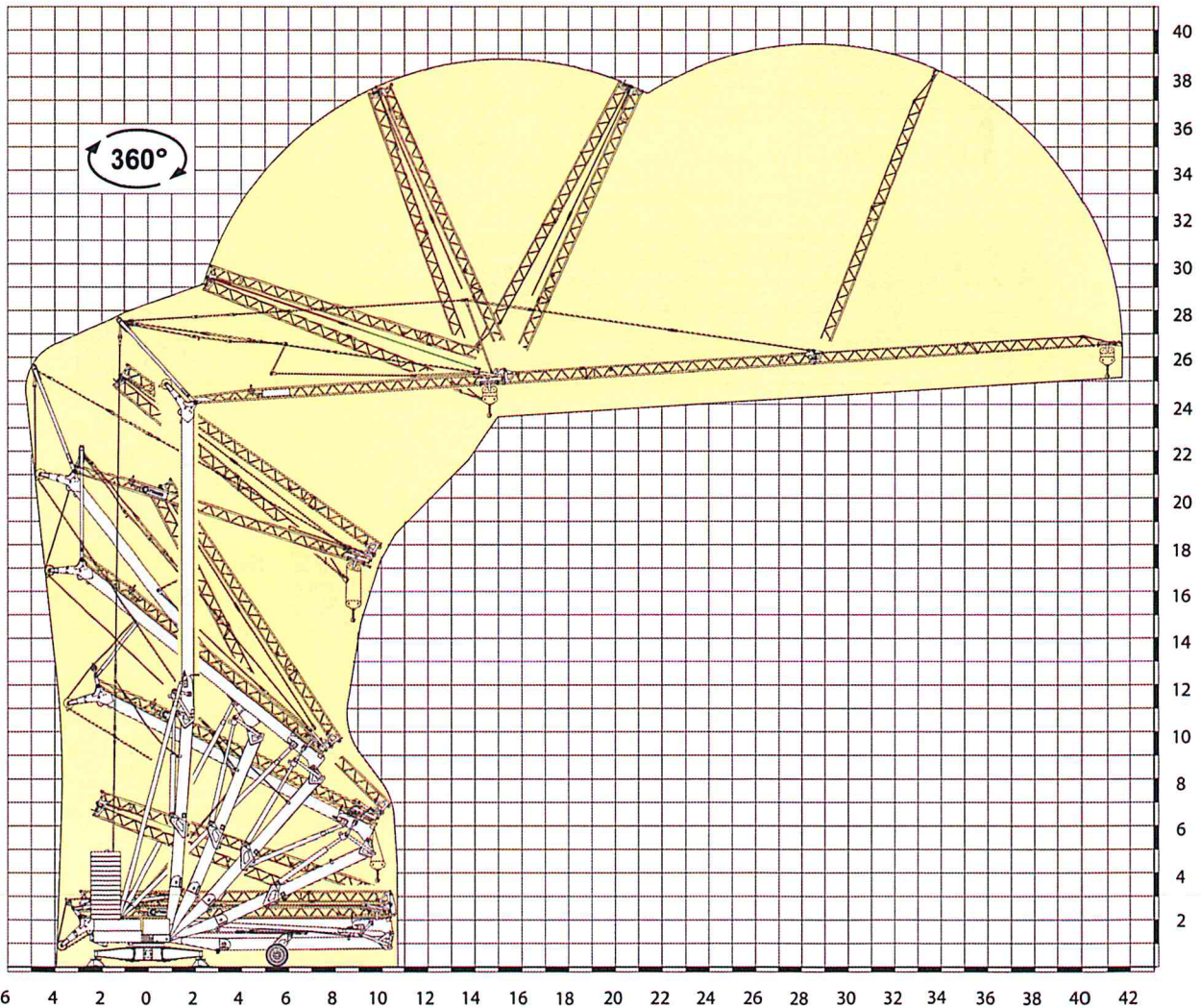

Contrappeso in lastre di cemento armato - Ferro-concrete ballast slabs
Contrepoids en plaques de béton armé - Gegengewicht aus Betonplatten - Lastre en hormigón armado

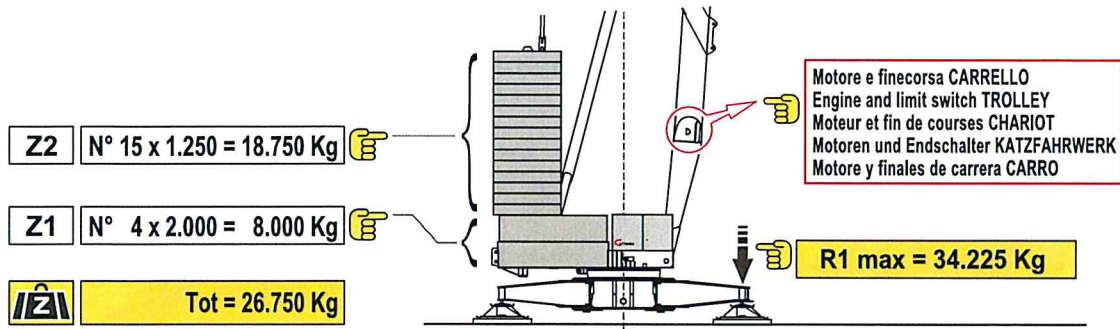

Trasporto - Transport - Transport - Transport - Transporte

19.350 kg Trasporto in sagoma su autoarticolato
 Transport in loading gauge on articulated lorry

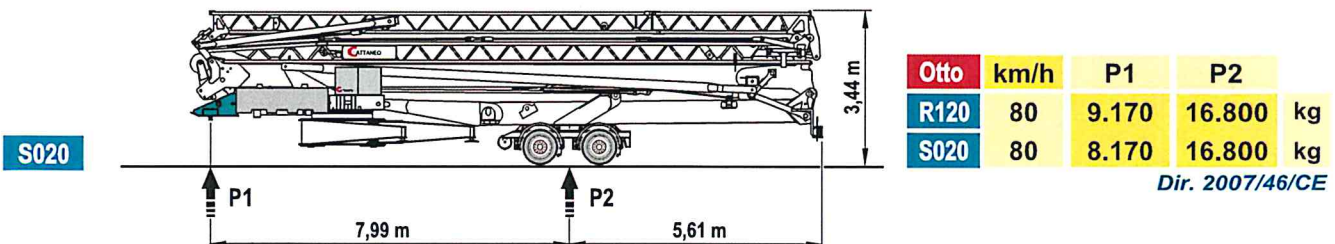
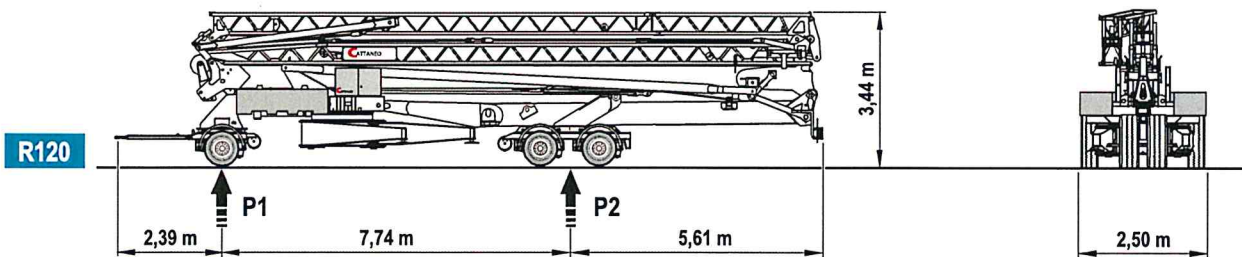
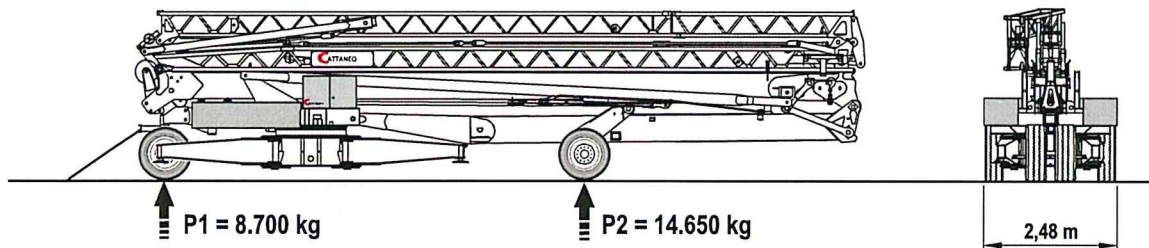
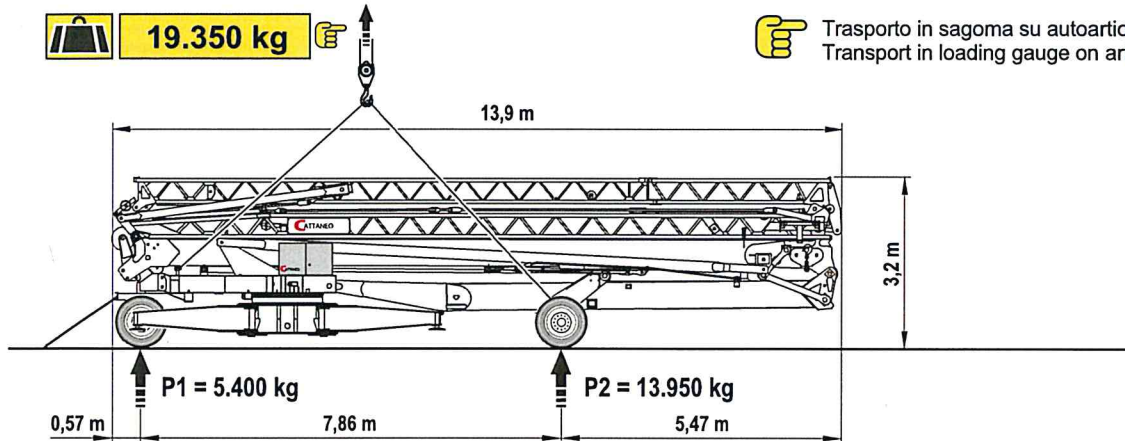

CATTANEO

Luigi Cattaneo S.p.A.
 via Trieste, 14 - 20020 Magnago (MI) Italia
 tel. +39 331 657132 - fax +39 331 305460
 www.cattaneogru.it - e-mail: cattgru@tin.it